

## Introduction to MLS

The Ex-Or Managed Lighting System is comprised of a comprehensive range of presence detectors and lighting control equipment designed to provide optimum lighting conditions, controllability and flexibility for office lighting projects of any size.

A two-wire communications bus connects all devices in order that they can share occupancy and control information; this gives greatly enhanced presence detection performance and facilitates a host of user-friendly control features such as automatic corridor linking (ie corridor lighting can be sustained by occupancy in other areas).

What sets the Ex-Or MLS apart from other bus-based systems is that the system is based upon *distributed intelligence*; this means that there is no central controller and no area controllers. All intelligence is in the 'local' devices; usually presence detectors.

The simplicity of this control philosophy leads to a system that is extremely reliable, easy to understand, commission and re-configure. Inherently low levels of bus traffic further enhance the robustness of communications. All configuration information is stored in non-volatile memory in the local devices and may be edited by non-expert personnel via infrared remote programming.

A major factor contributing to system reliability is the optical isolation of the bus network at each device. However, this limits the extent of a basic network to 200 devices and necessitates the use of a Bus Power Supply. Larger systems can be constructed easily by linking basic networks together.

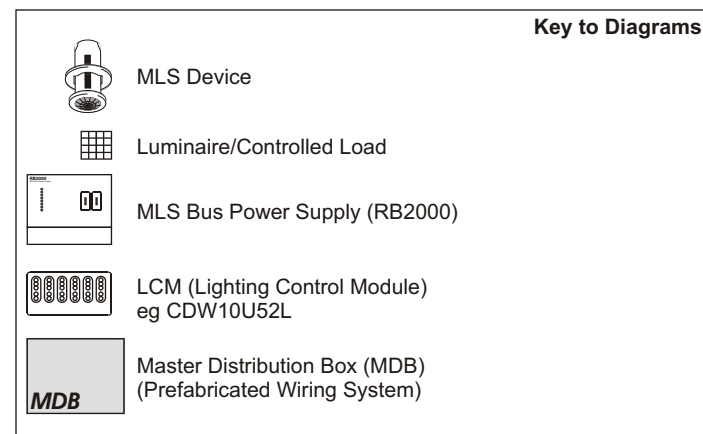

## Example of a Basic Network

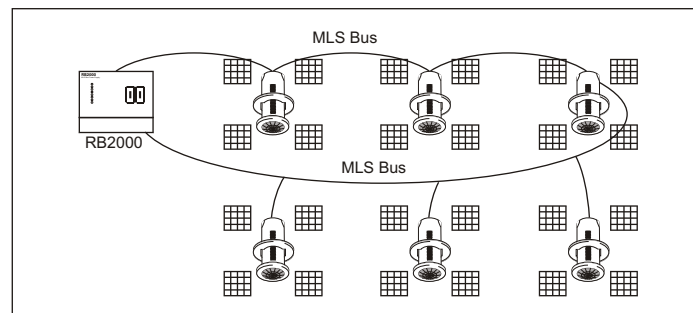

A basic network, consisting of a single Bus Power Supply and a number of presence detectors controlling groups of luminaires. No additional equipment is installed on the network.

The wiring topology shown incorporates a ring with several short spurs.

## Example of a Larger System

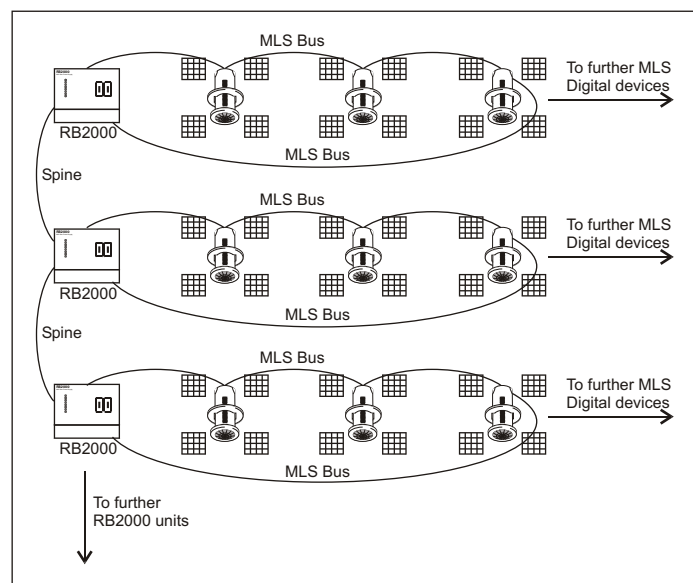

Three Bus Power Supplies are shown connected together via the 'Spine' allowing occupancy information from each floor in a typical office to be shared as a building-wide 'Common Zone'

Building-wide common areas such as stairwells will remain on whenever any part of the building is occupied.

Any movement detected by one or more presence detectors will keep lighting in common areas on for that period of occupancy. Notional corridors may be configured where the layout of the office is subject to frequent change.

The Spine should be wired using Belden cable type 9502NH (available from RS, 382-7303). The spine should be wired in a daisy chain - spurs from the Spine are not permitted. Maximum length = 1000m

## Wiring topology

Another great advantage of the Ex-Or MLS System is that the bus may be wired with a free topology; this means that any wiring configuration may be used so long as everything is connected. No terminations are necessary.

The choice of topology does, however, determine the required gauge of cable and maximum length. Ease of fault finding at the installation stage, and ease of future modification are also considerations.

Please note that the MLS bus is polarity conscious unless otherwise stated in the product installation instructions.

## Example of Rat's Nest topology

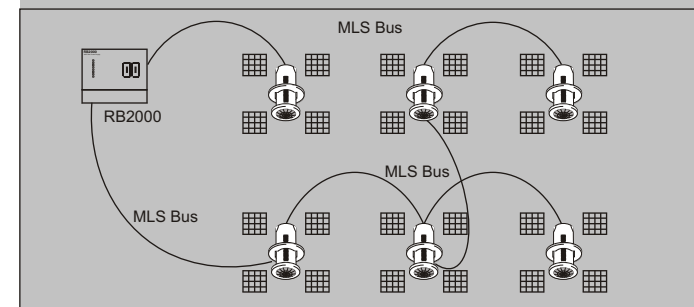

**Advantages:**  
Easy and carefree to wire  
Easy to extend

**Disadvantages:**  
Difficult to find installation faults  
Difficult to calculate maximum cable length for any given wire gauge

## Example of Ring topology (with short spurs)

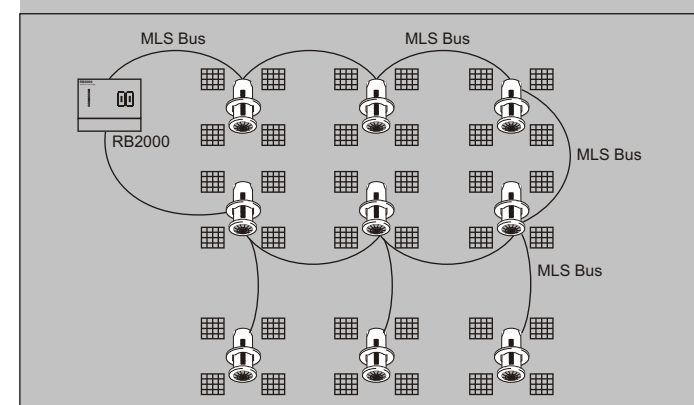

Maximum length of ring	Conductor size
1500m	1.5mm <sup>2</sup>
800m	1.0mm <sup>2</sup>

## Advantages:

Easy to test the integrity of the ring  
Relatively long length of cable allowed  
Relatively easy to extend

## Disadvantages:

Not so appropriate for awkward-shaped buildings

## Example of Radial topology

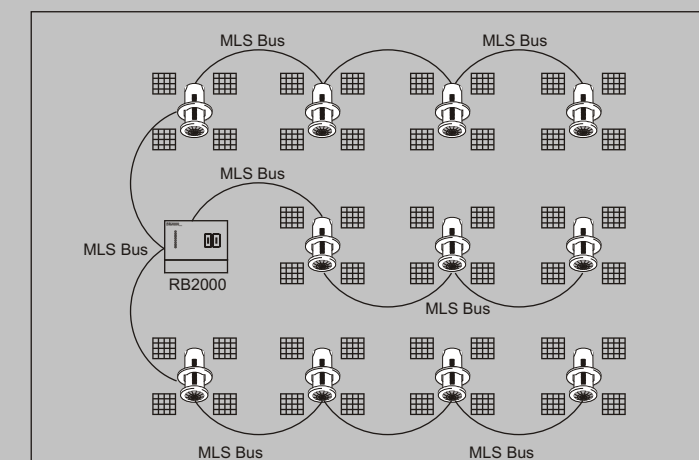

Maximum length of each radial	Conductor size
500m	1.5mm <sup>2</sup>
300m	1.0mm <sup>2</sup>

Maximum number of radials: no practical limit

## Advantages:

Best for awkward-shaped buildings  
Practically no restriction to the total amount of cable  
Easy to extend

## Disadvantages:

Not as easy to fault-find as ring topology

## Example of Prefabricated Wiring topology

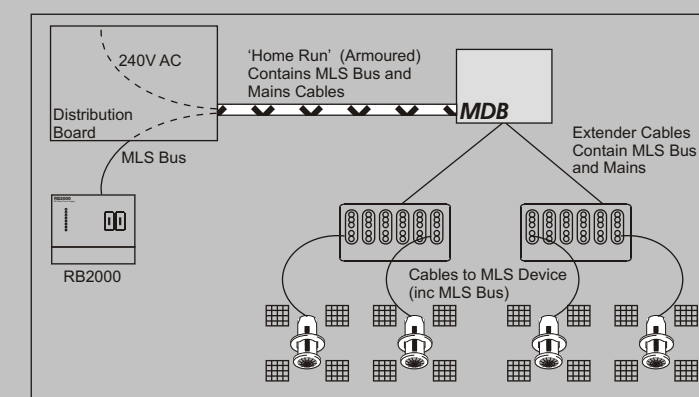

Continued Overleaf...

### Example of Prefabricated Wiring topology (continued from previous page)

Max no. of 'home runs': no practical limit

If the MLS Bus cable is included within the home run armouring the cable must be **twisted-pair** in order to prevent noise coupling from the mains conductors.

Longest length from Bus PSU Conductor size

500m	1.0mm <sup>2</sup>
300m	0.7mm <sup>2</sup>

Max total length of cable: 1000m (if MLS Bus cable within the extender cable is screened)

#### Advantages:

This is essentially a radial topology with all its advantages  
There should be no wiring faults

#### Disadvantages:

Often the bus cable is thin and screened which limits the maximum length of each radial and the total amount of bus cable on the system.

### MLS Cable type

Ex-Or recommend the use of MLS-SensaLink cable from UK Cables Ltd 0161 653 6789

#### Specification:

Two-core multi-stranded twisted pair  
Cross-sectional area \*1.5mm<sup>2</sup>  
Unscreened  
600/1000V rated  
LSOH insulated

This cable is manufactured to a 'catch all' specification, which will be suitable for *all* MLS applications. Often, an application will not require ultimate performance in one or more cable parameters; the information in this section should enable the suitability of alternative cables to be evaluated. However, if there is any doubt, the 'catch all' cable should be used.

#### Cross sectional area

This is the most important parameter, as volt-drop must be minimised. This parameter is totally dependent upon the wiring topology and length of cable run. Please read the section on different wiring topologies. Ex-Or does not recommend or approve the use of cable less than 1.0mm<sup>2</sup> under any circumstances.

### Twisted pair

This is necessary only when the bus cable is run with mains for distances greater than approximately 20m. If the bus cable is not run with mains it is perfectly acceptable to use normal two-core flex or 'twin and earth' - cutting out the earth at each junction. **Single wires (as opposed to cable) must never be used.**

### Screening

The screening causes excessive capacitance between the conductors and degrades the signal, limiting cable run length. Screened cable used in the extender cables of certain manufacturers' prefabricated systems has been tested and approved by Ex-Or. **(No other screened cable is acceptable)**

### Voltage rating

Wiring regulations state that cable should be rated to the same voltage as that appearing on any other cable sharing the same containment. The MLS cable may be run with mains cable on different phases, provided suitably rated cable is used.

### Insulation

The 'catch all' specification calls for LSOH insulation. Naturally PVC or any other suitable insulation can be used where LSOH is not required.

### AWG - Approximate metric equivalents

AWG	mm <sup>2</sup>
14	2.08
15	1.65
16	1.30
17	1.0
18	0.8
19	0.65
20	0.52



### MLS2000 Wiring Application Note AN4001



### Notes

This application note is intended for use in conjunction with Ex-Or's range of MLS2000 series detectors and ancillary equipment.

Products from the MLS1200 series are not compatible with equipment specified in this document.